

Mobile Foam trailer S100



Mobile trolley for foaming liquids consisting of a shock-resistant red polyethylene tank with capacity of **110 lt.**

Painted tubular steel frame mounted on pneumatic wheels.

Level indicator band and foam filter.

BYPP 200 in-line mixer with 3/6% fixed doser and non-return valve.

Unified connections M / F 45 UNI 804.

Low expansion foam nozzle "Kugel foam 200" nominal flow rate 200 l / min.

N° 2 pipes diameter 45 of 20 m in accordance with UNI 9487 complete with fittings for connecting the hydrant-mixer-lance.

Toolbox included.

TECHNICAL DATA :

Nominal flow rate: 100 lt.

Expansion ratio: 1: 10/12.

Discharge time: 8/16 min.

Foam range: 10-16 m.

Weight (empty): 51 kg.

Dimensions: 1200x770x850.

Minimum pressure: 0,3 MPa

Components :

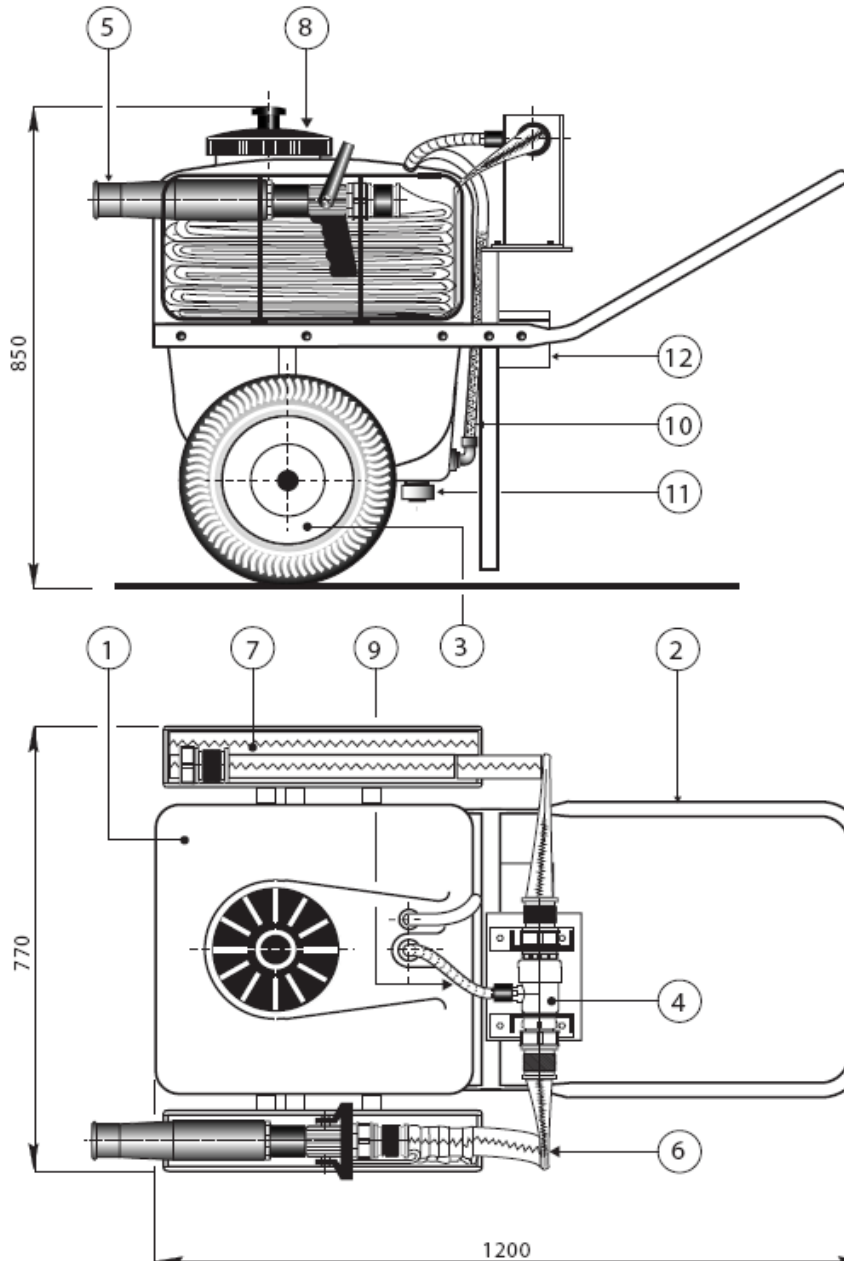

Pos.	Descrizione
1	Serbatoio 110 lt.
2	Telaio
3	Ruote pneumatica
4	Miscelatore di linea
5	Lancia "Kugel foam 200"
6	Tubazione colleg. lancia
7	Tubazione colleg. idrante
8	Tappo di carica con filtro
9	Tubo pescante
10	Indicatore di livello
11	Tappo di scarico
12	Cassetta porta-attrezzi